

Developing lake-specific nutrient criteria: *Integrating predictive modeling with biological response gradients*



Patricia A. Soranno, Kendra Spence Cheruvelil,
R. Jan Stevenson, Scott L. Rollins, Sarah W. Holden,
Sylvia Heaton, and Eric Torng

March 15, 2007



MICHIGAN STATE
UNIVERSITY

Michigan Nutrient Criteria Groups

MI-DEQ Workgroup:

Management

Sylvia Heaton
Sarah Holden
Ralph Bednarz
*Candice Bauer, EPA

Lakes (MSU)

Patricia Soranno
Kendra Cheruvelil

Streams (MSU)

R. Jan Stevenson
Scott Rollins

MI-DEQ Implementation:

Management (additional):

Diana Klemans
Gerald Saalfeld
Brenda Sayles
William Creal
Eric Alexander

Acknowledgements

Funding:

- MI Department of Environmental Quality
- MSU Agricultural Experiment Station Disciplinary grant

GIS processing and data:

- M. Belligan, J. Booth, J. Breck, L. Kraft, D. Lusch

Lake database management and information:

- S. Holden , J. Smith, and H. Wandell

Biological databases:

- M. Bremigan , A. Jubar, L. Knoll, S. Martin and C. Scheele

Outline

1. Background: challenges of setting nutrient criteria
2. Overview of our approach
3. Specific methods and results of this approach applied to Michigan lakes
4. Concluding remarks

Background

Nutrient Criteria

= numerical values for both causative (e.g. phosphorus) and response (e.g. chlorophyll) variables to prevent and assess eutrophic conditions.

EPA suggests:

- *ecoregion approach*
- *classification*
- *modeling*
- *current reference sites*

The **lake-specific nutrient criteria** (LNC) approach

Strengths

1. Synthetic approach – incorporates biology, ecoregion & local landscape features
2. Recognizes that prior to human disturbance, lakes varied in their ‘reference’ TP concentration
3. Incorporates risk into the decision-making process
4. Can incorporate new data and models as they become available

Background

Challenges of developing nutrient criteria in lakes

- What are 'reference' nutrient levels in lakes, and how much do they vary?

Lakes

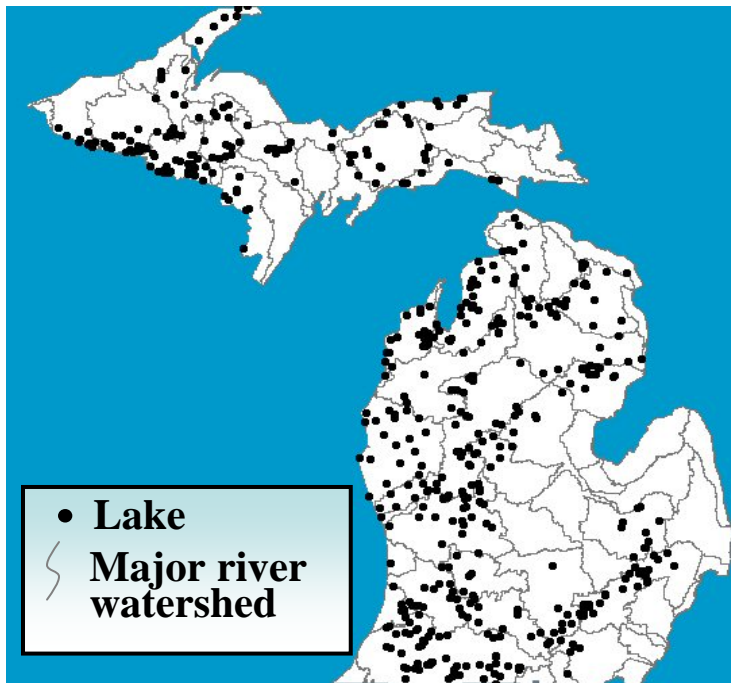

Surficial geology



Background

Challenges of developing nutrient criteria in lakes

- How does biology respond to increasing nutrients?

Linear

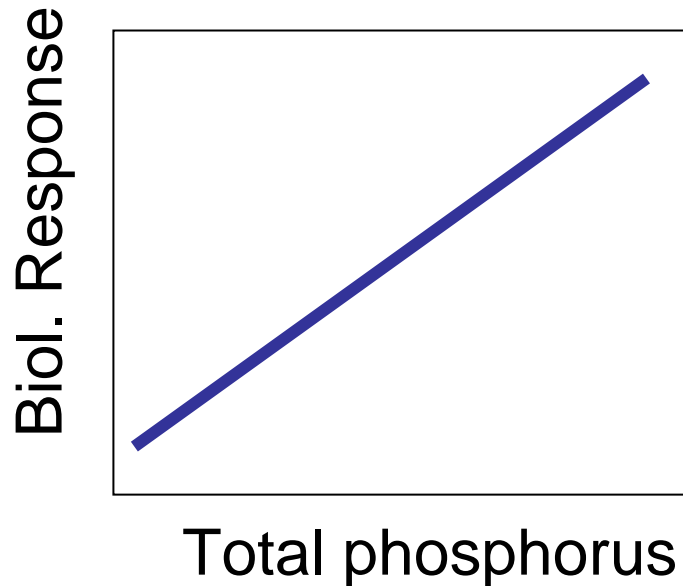

- OR -

Nonlinear

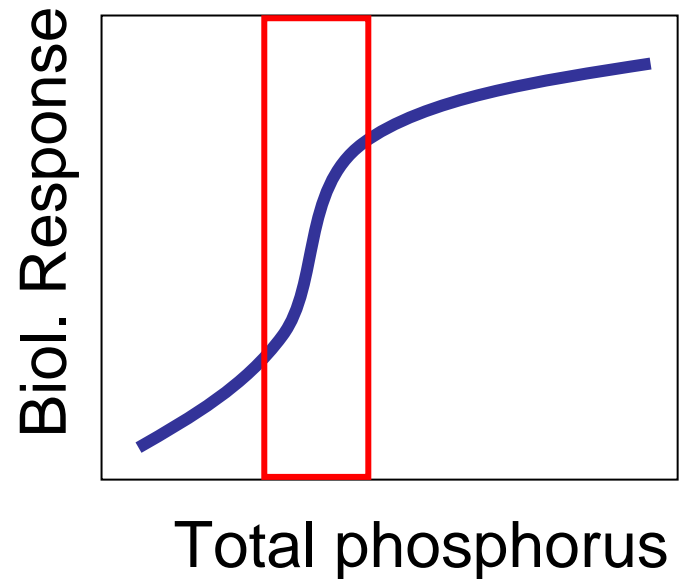

Background

Challenges of developing nutrient criteria in lakes

- How does biology respond to increasing nutrients?
- What is the uncertainty surrounding the threshold?

Linear

Biol. Response

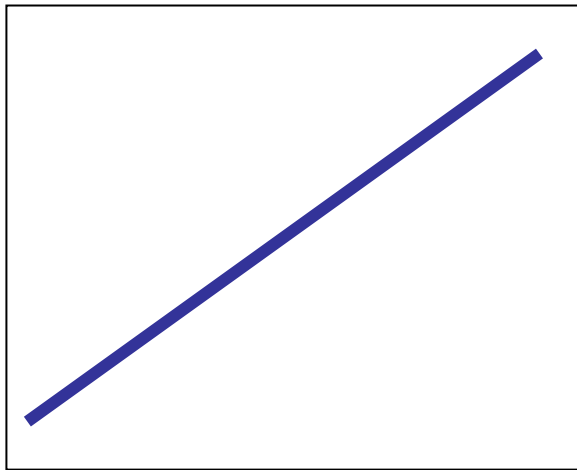

Total phosphorus

- OR -

Nonlinear

Biol. Response

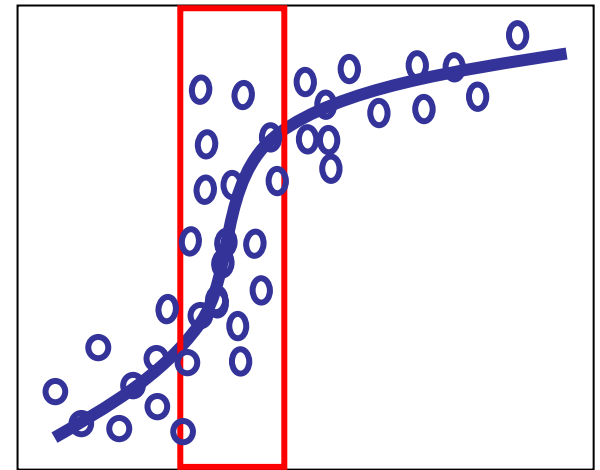

Total phosphorus

Background

Challenges of developing nutrient criteria in lakes

- How do you incorporate updated information?

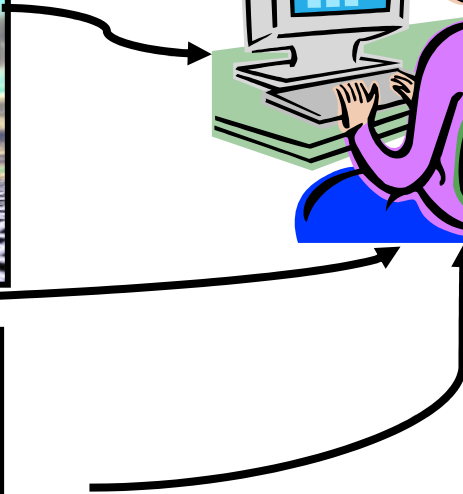
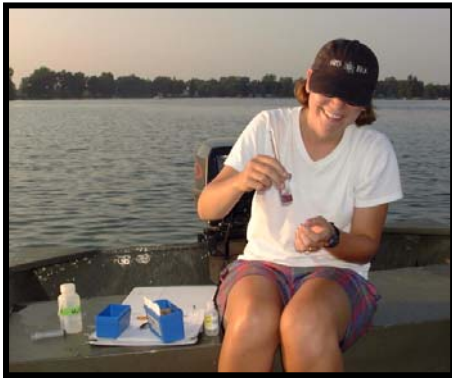

Background

Challenges of developing nutrient criteria in lakes

- How do you incorporate updated information?

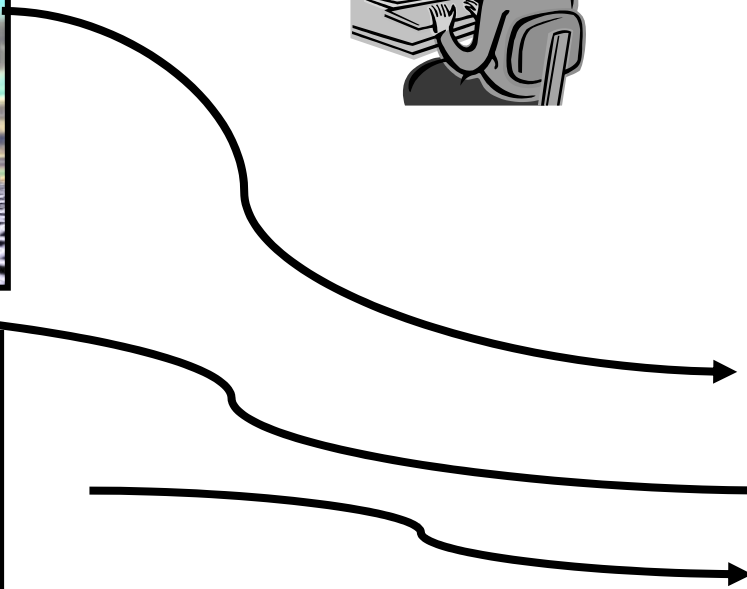
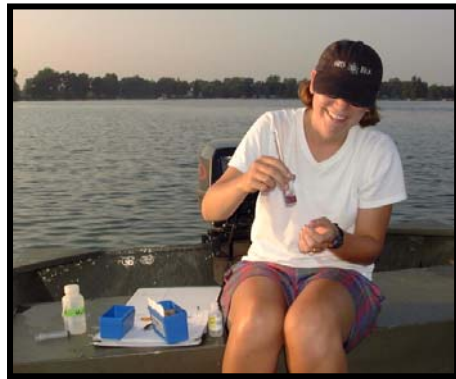

The lake-specific nutrient criteria (LNC) approach

Overview

1. Model current lake TP



2. Predict lake 'expected condition' (TP)



3. Identify thresholds in biological responses to TP



4. Use LNC algorithm to develop lake-specific criteria

≈ Reference condition

3 Databases: Michigan lakes

374 'natural' lakes

1. Water chemistry database (summer values):
TP, TN, chlorophyll, Secchi, alkalinity, water color
2. Biological response database (summer values):
Smaller datasets of biological responses
3. GIS Landscape database:
 - Surficial/bedrock geology
 - Climate
 - Land use/cover
 - Catchment morphometry
 - Lake morphometry

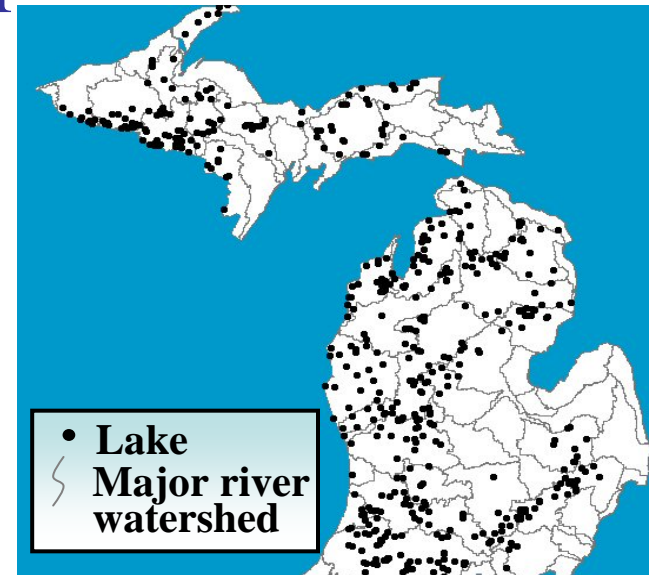

The lake-specific nutrient criteria (LNC) approach

Overview

1. Model current lake TP

```
graph TD; A[1. Model current lake TP] --> B[2. Predict lake 'expected condition' (TP)]; B --> C[3. Identify thresholds in biological responses to TP]; C --> D[4. Use LNC algorithm to develop lake-specific criteria];
```

2. Predict lake 'expected condition' (TP)

3. Identify thresholds in biological responses to TP

4. Use LNC algorithm to develop lake-specific criteria

LNC approach

Phosphorus loading concept

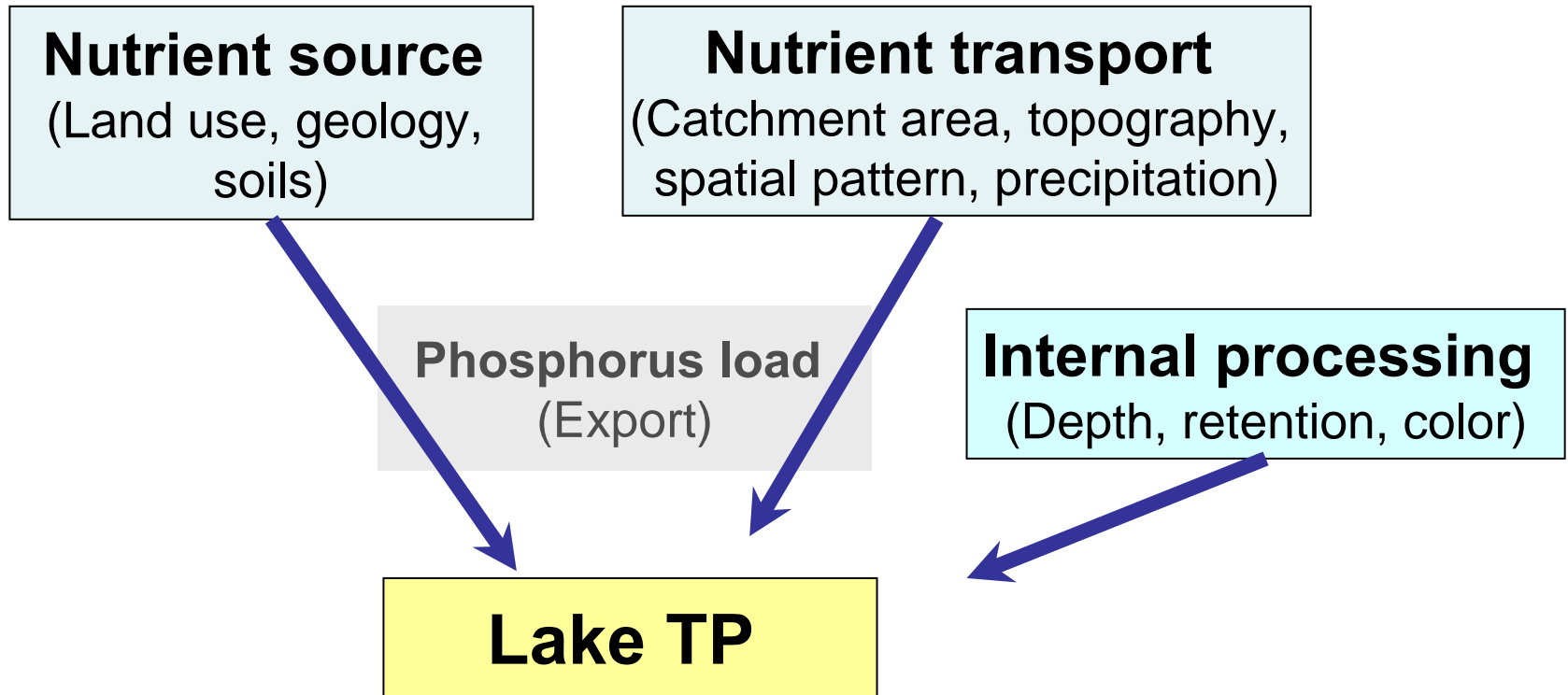

LNC approach

Hydrogeomorphic-land use model

Model form: Multiple regression

Response variable: Lake summer TP

Predictor variables:

- GIS-based landscape data
(*land use/cover, geology, climate, etc.*)
- catchment morphometry
- lake morphometry
- lake chemistry (*alkalinity & water color*)

LNC approach

Model results for 374 lake dataset

CURRENT TP = 1.867 - 0.257 x (ln(mean depth))
- 0.202 x (surficial geology)
+ 0.344 x (ln(water color))
+ 1.125 x (% agriculture)
+ 1.233 x (% urban)
+ error

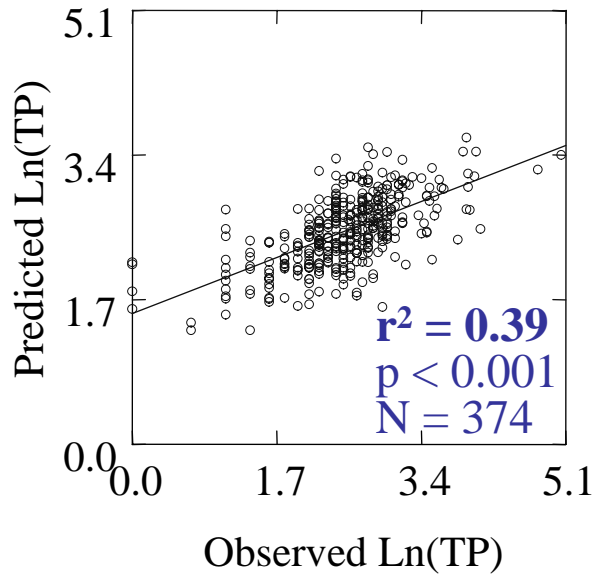

~~ecoregion
climate
catchment morph.~~

The lake-specific nutrient criteria (LNC) approach

Overview

1. Model current lake TP



2. Predict lake 'expected condition' (TP)



3. Identify thresholds in biological responses to TP



4. Use LNC algorithm to develop lake-specific criteria

≈ Reference condition

LNC approach

Predictions for 374 lake dataset

EXP₀ = Lake TP in the *least disturbed condition*
given the state of today's landscape

$$\begin{aligned} \mathbf{EXP}_0 = & 1.867 - 0.257 \times (\ln(\text{mean depth})) \\ & - 0.202 \times (\text{surficial geology}) \\ & + 0.344 \times (\ln(\text{water color})) \\ & + 1.125 \times (0\% \text{ agriculture}) \\ & + 1.233 \times (0\% \text{ urban}) \\ & + \text{error} \end{aligned}$$

LNC approach

Predictions for 374 lake dataset

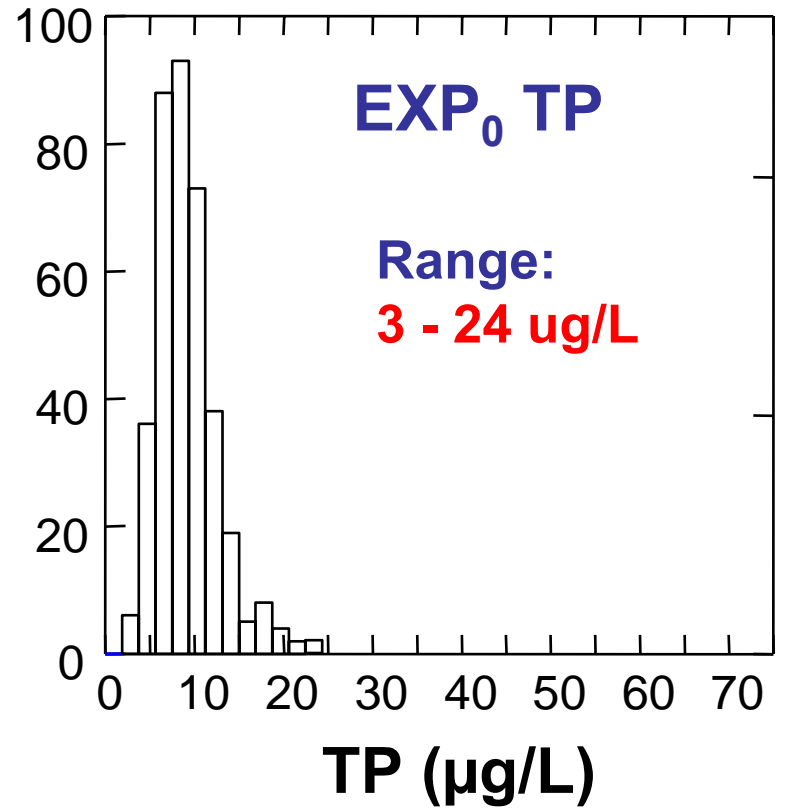
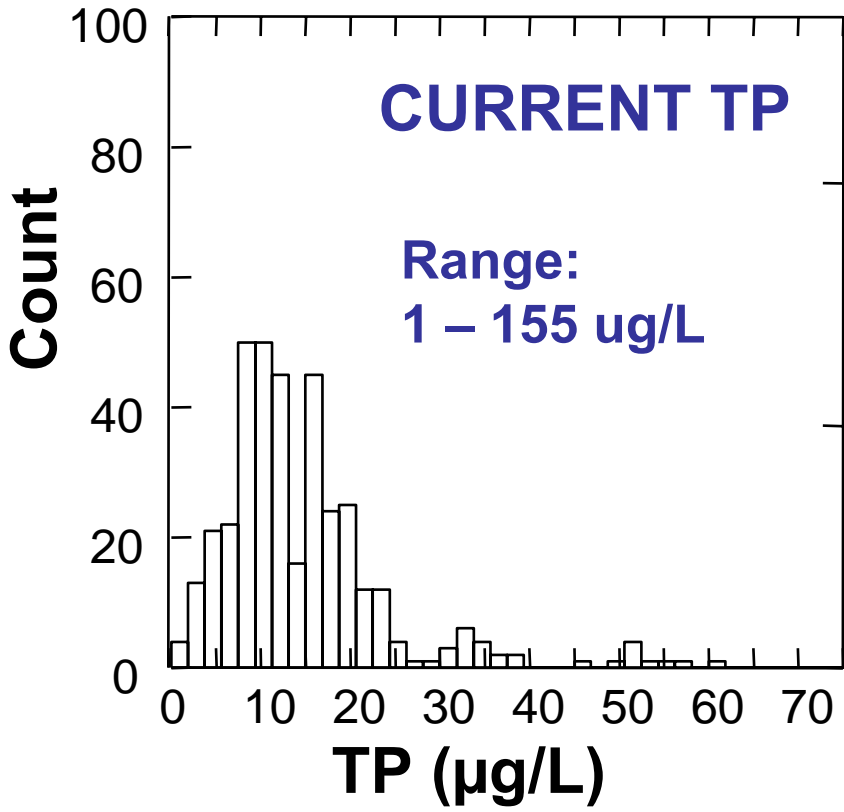

LNC approach

Predictions for 374 lake dataset

$$\mathbf{EXP}_A = \mathbf{EXP}_0 + \text{'Allowance'}$$

'Allowance' = some low or minimal level of allowable human disturbance to the lake

'Allowance' = upper 75th confidence interval from the TP model

LNC approach

Predictions for 374 lake dataset

$$EXP_A = EXP_0 + \text{'Allowance'}$$

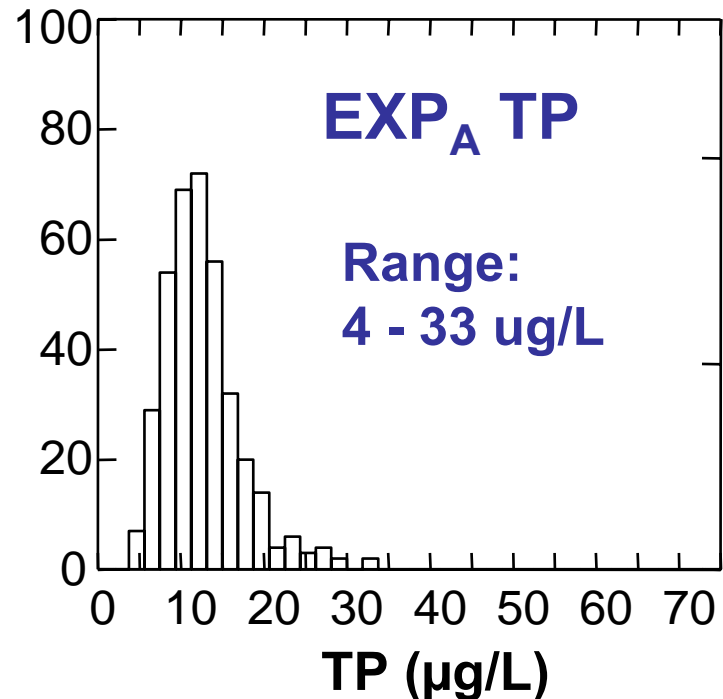
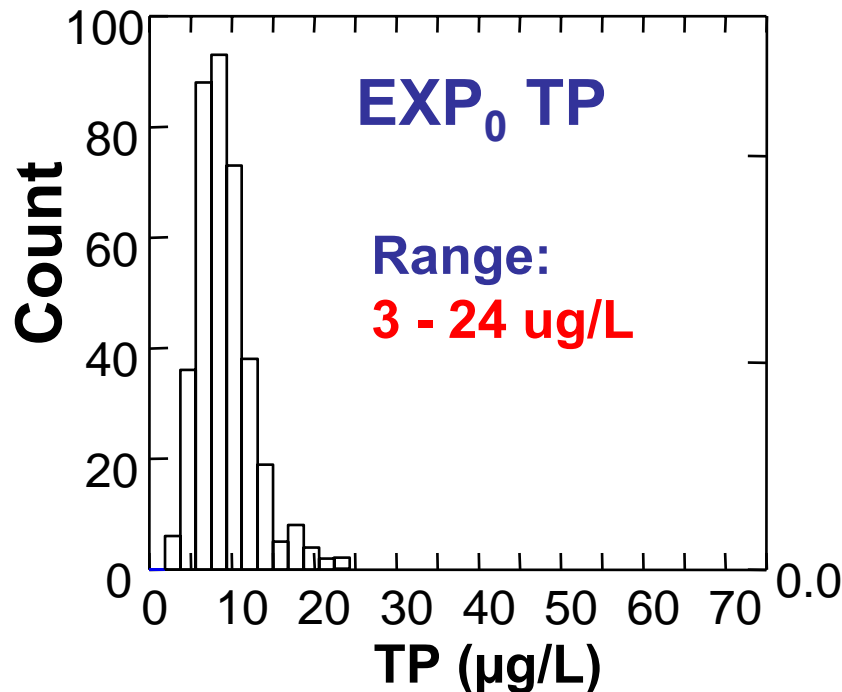

The lake-specific nutrient criteria (LNC) approach

Overview

1. Model current lake TP

```
graph TD; A[1. Model current lake TP] --> B[2. Predict lake 'expected condition' (TP)]; B --> C[3. Identify thresholds in biological responses to TP]; C --> D[4. Use LNC algorithm to develop lake-specific criteria];
```

2. Predict lake 'expected condition' (TP)

3. Identify thresholds in biological responses to TP

4. Use LNC algorithm to develop lake-specific criteria

LNC approach

Overview

Quantify:

1. **Thresholds** = points where there is an abrupt change in a lake response (nonlinear).
2. **Risk** = The proportion of thresholds less than a given TP threshold.
3. **BIO benchmark** = TP level where an important change in the biological community has occurred.

Quantifying thresholds

- 1) Use Regression Tree Analysis (RTA) to identify nonlinear relationship (thresholds).
- 2) If it is a moderate to strong relationship ($FIT \geq 0.30$), then do the following.

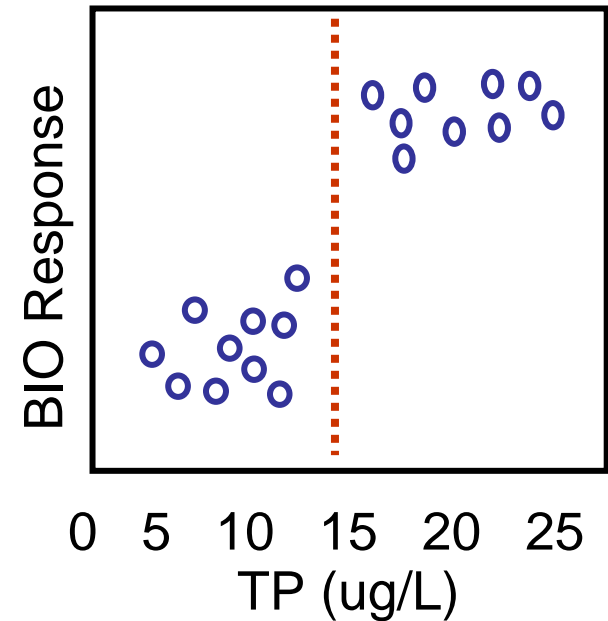

Quantifying thresholds & risk

3) Resample the dataset and create 1000 datasets, each of the same sample size and calculate a threshold for each dataset.

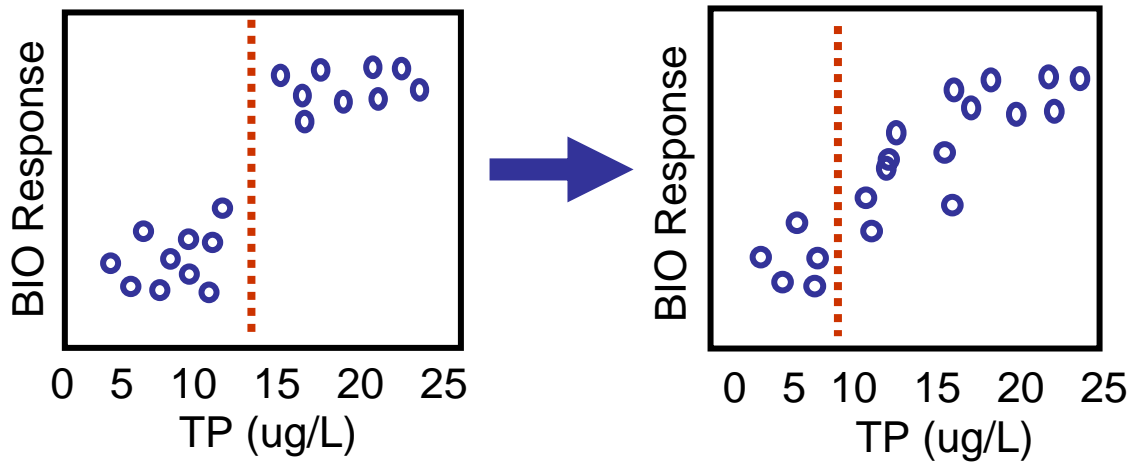

4) Quantify the proportion of thresholds lower than a given TP value.

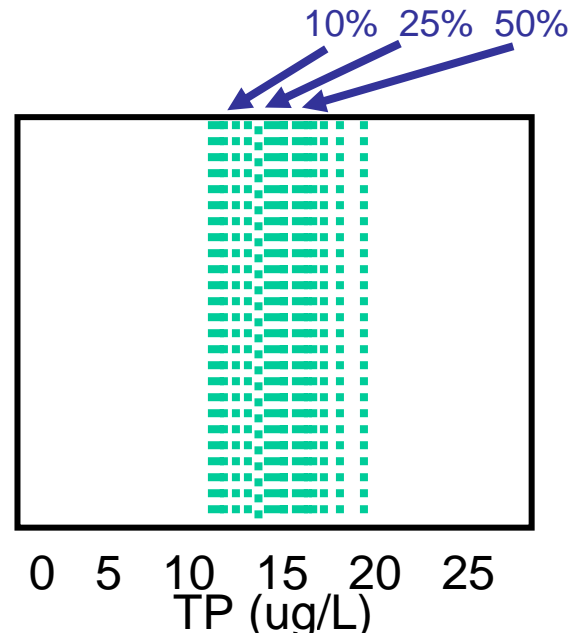

3. Identify thresholds in biological responses to TP

Quantifying risk

1) TP Benchmark Risk =

The proportion of thresholds less than a given TP Benchmark.

Given a TP benchmark of ~11 ug/L, 18% of bootstrapped thresholds are lower than 11 ug/L.

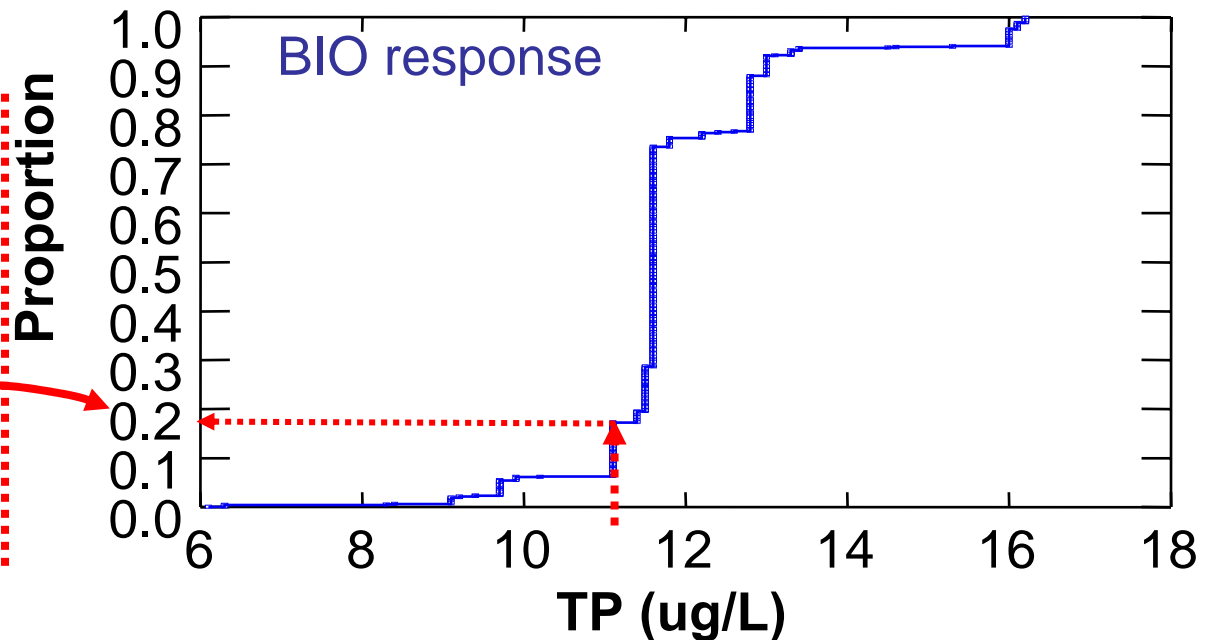

2) Quantify risk at 1%, 10% and 50% levels for each BIO response

Quantifying thresholds

MI BIO datasets

1. **Chlorophyll a**
2. **Water clarity:** Secchi depth and extinction coefficient
3. **Phytoplankton community** (5 metrics): biomass, nuisance species, toxin producing species, etc..
4. **Micro zooplankton** (5 metrics): biomass, species abundance, etc.
5. **Macro zooplankton** (34 metrics): biomass, species abundance, lengths
6. **Aquatic plants** (9 metrics): plant cover, etc.
7. **D.O.** (3 metrics): anoxia in hypolimnion

Quantifying thresholds

Results for MI BIO datasets

Chlorophyll

34 ← Threshold

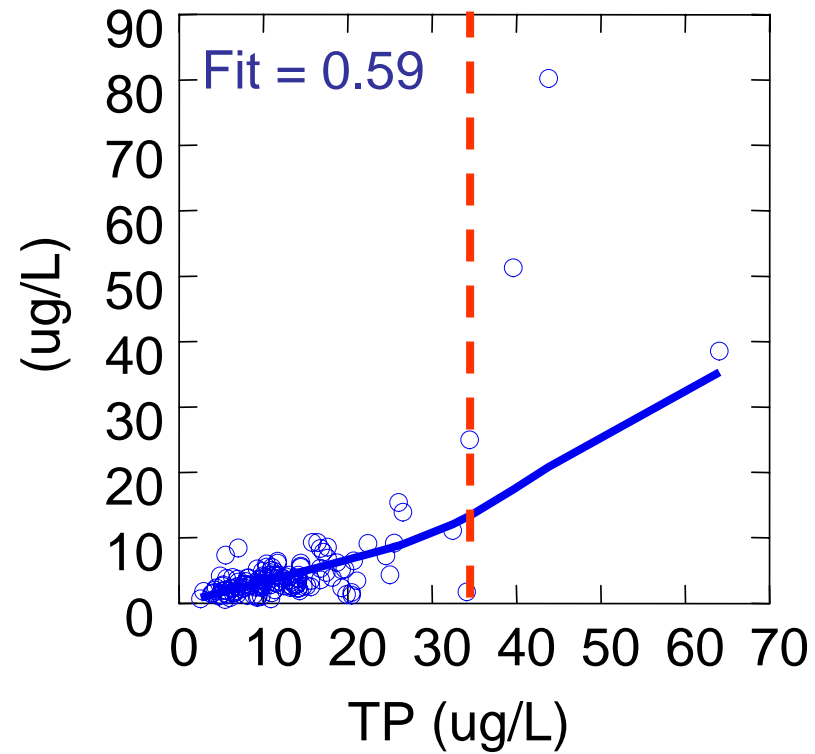

Quantifying thresholds

Results for MI BIO datasets

Chlorophyll

% *Daphnia* biomass

34 ← Thresholds → 12,17

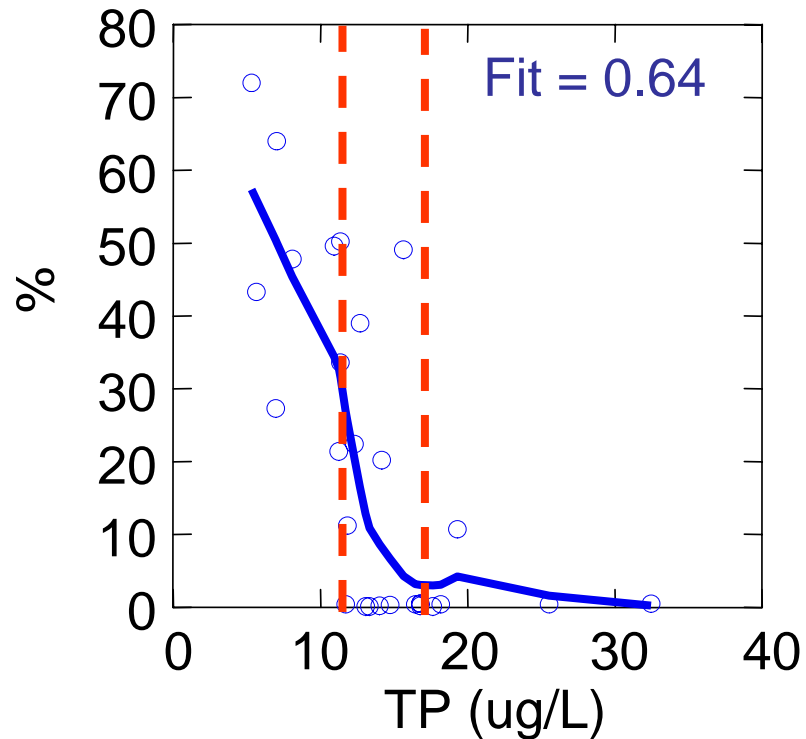
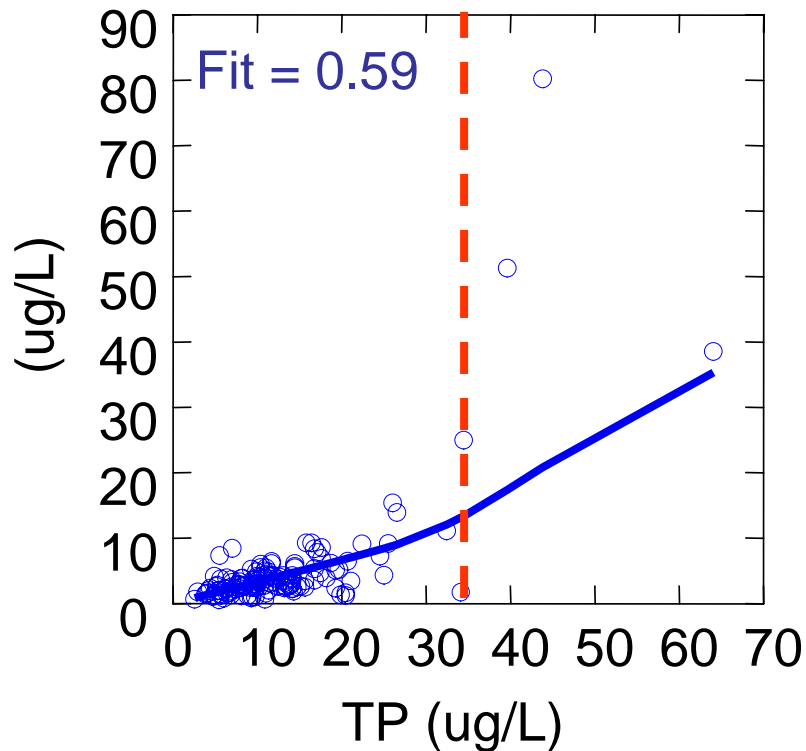

Quantifying thresholds

Results for MI BIO datasets

BIO response variable	RTA thresholds - TP (ug/L)	RTA - FIT	Linear Regr. r^2	# Lakes
<u>Phytoplankton and clarity</u>				
Chlorophyll <i>a</i> (ug L ⁻¹)	34	0.59	0.42	140
Phytoplankton biomass (ug L ⁻¹)	27	0.78	0.44	56
Extinction coefficient (m ⁻¹)	27	0.71	0.47	64
Secchi depth (m)	6, 11, 22	0.32	0.29	153
<u>Zooplankton</u>				
Cladoceran mean length (mm)	11, 15	0.43	ns	43
% Daphnia biomass	12, 17	0.64	0.53	28
Zooplankton biomass (ug L ⁻¹)	13, 16	0.30	0.21	28

Quantifying thresholds

Results for MI BIO datasets

BIO response variable	RTA thresholds - TP (ug/L)	RTA - FIT	Linear Regr. r^2	# Lakes
<u>Phytoplankton and clarity</u>				
Chlorophyll <i>a</i> (ug L ⁻¹)	34	0.59	0.42	140
Phytoplankton biomass (ug L ⁻¹)	27	0.78	0.44	56
Extinction coefficient (m ⁻¹)	27	0.71	0.47	64
Secchi depth (m)	6, 11, 22	0.32	0.29	153
<u>Zooplankton</u>				
Cladoceran mean length (mm)	11, 15	0.43	ns	43
% Daphnia biomass	12, 17	0.64	0.53	28
Zooplankton biomass (ug L ⁻¹)	13, 16	0.30	0.21	28

Quantifying risk

Results for MI BIO datasets

Bootstrapped thresholds

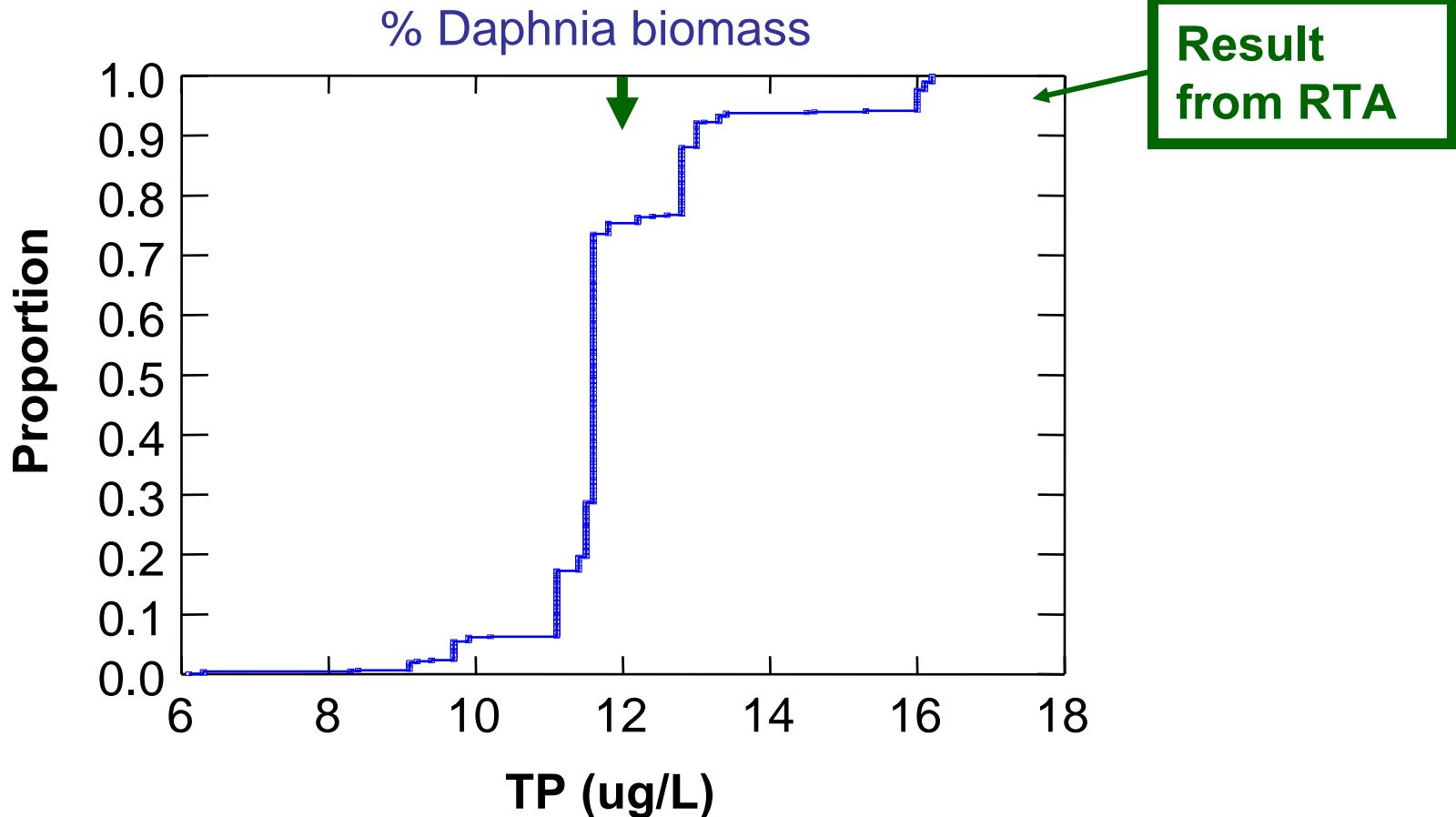

Quantifying risk

Results for MI BIO datasets

Bootstrapped thresholds

% Daphnia biomass

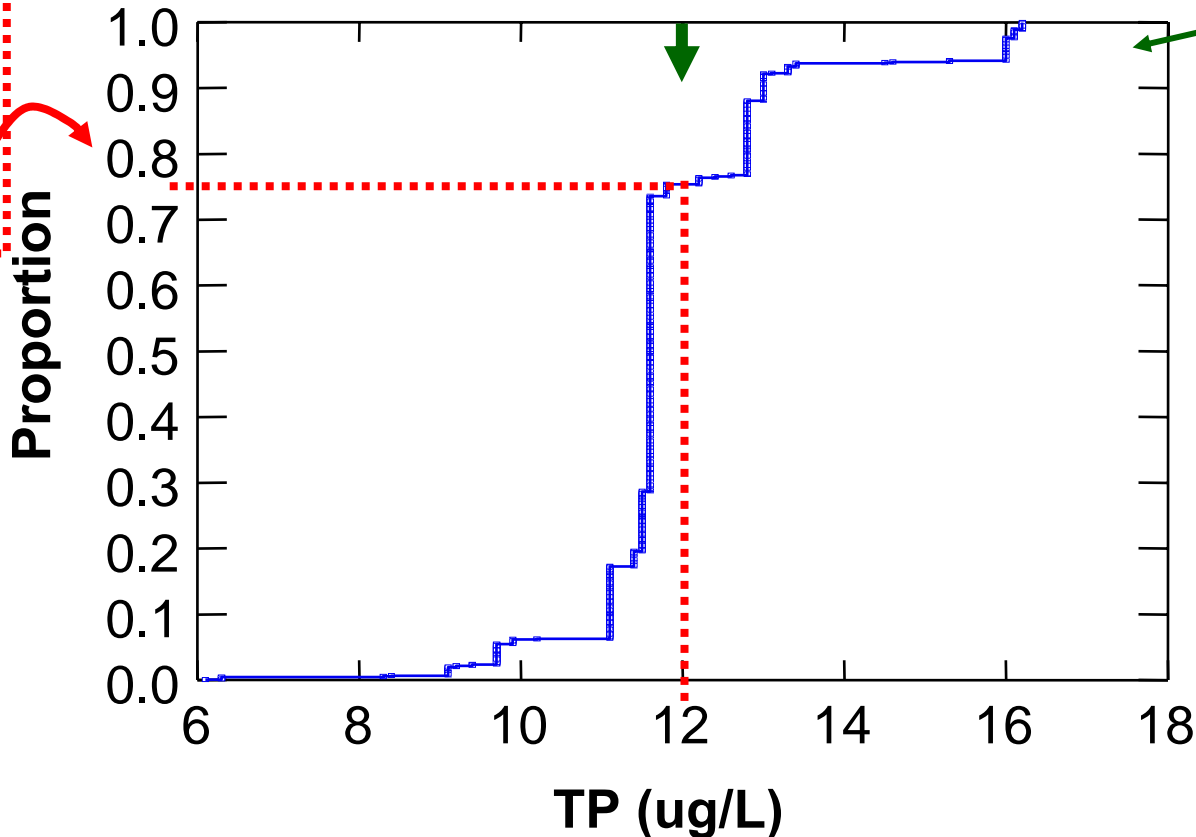

Given a TP benchmark of 12 ug/L, ~78% of thresholds are lower.

Result from RTA

Quantifying risk

Results for MI BIO datasets

Bootstrapped thresholds

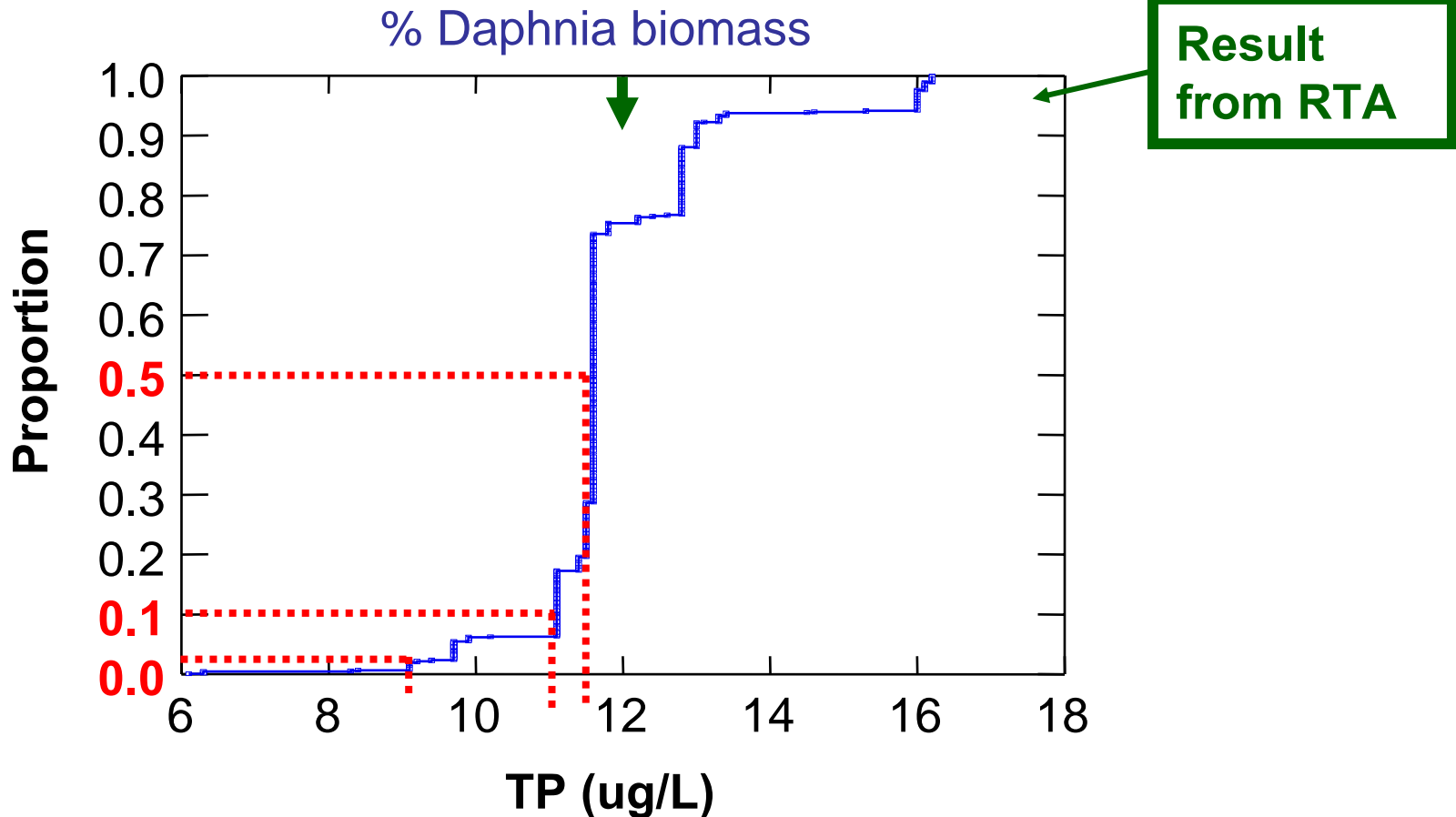

Quantifying risk

Results for MI BIO datasets

Risk:

BIO response	1%	10%	50%	<u>RTA:</u>
Phytoplankton/clarity	<u>TP</u>	<u>TP</u>	<u>TP</u>	
Chlorophyll	16	26	34	34

Quantifying risk

Results for MI BIO datasets

Risk:

BIO response	1%	10%	50%	<u>RTA:</u>
Phytoplankton/clarity	<u>TP</u>	<u>TP</u>	<u>TP</u>	
Chlorophyll	16	26	34	34
Phyto biom.	16	20	30	27
Ext. coeff.	12	21	33	27
Secchi	5	6	11	11
Zooplankton				
Clad Len	6	8	11	11
% Daph Biom	9	11	12	12
Zoop Biom	8	8	13	13

Choosing BIO benchmarks

Results for MI BIO datasets

Risk:

BIO response	1%	10%	50%		N	<i>Importance</i>	<i>Quality</i>	<i>Resp. factor</i>
Phytoplankton/clarity	<u>TP</u>	<u>TP</u>	<u>TP</u>					
Chlorophyll	16	26	34		140			
Phyto biom.	16	20	30		56			
Ext. coeff.	12	21	33		64			
Secchi	5	6	11		153			
Zooplankton								
Clad Len	6	8	11		43			
% Daph Biom	9	11	12		28			
Zoop Biom	8	8	13		28			

Choosing BIO benchmarks

Calculating BIO response factors

- **BIO Response factor** = $\frac{\text{Median of BIO above threshold}}{\text{Median of BIO below threshold}}$
- **Relevant BIO response** = Factor of 2

Choosing BIO benchmarks

Calculating BIO response factors

- **BIO Response factor** = $\frac{\text{Median of BIO above threshold}}{\text{Median of BIO below threshold}}$
- **Relevant BIO response** = Factor of 2

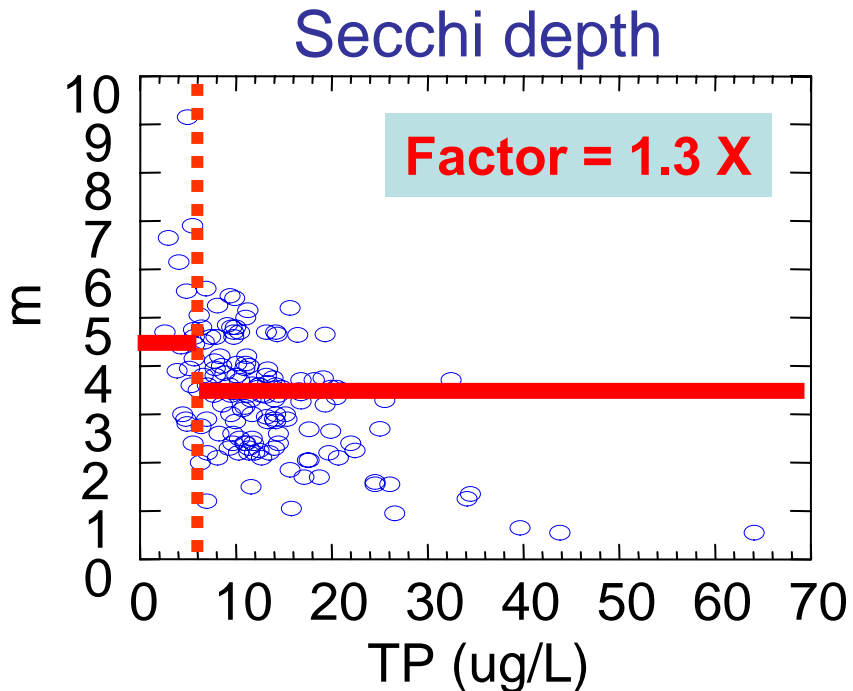

Choosing BIO benchmarks

Calculating BIO response factors

- **BIO Response factor** = $\frac{\text{Median of BIO above threshold}}{\text{Median of BIO below threshold}}$
- **Relevant BIO response** = Factor of 2

Secchi depth

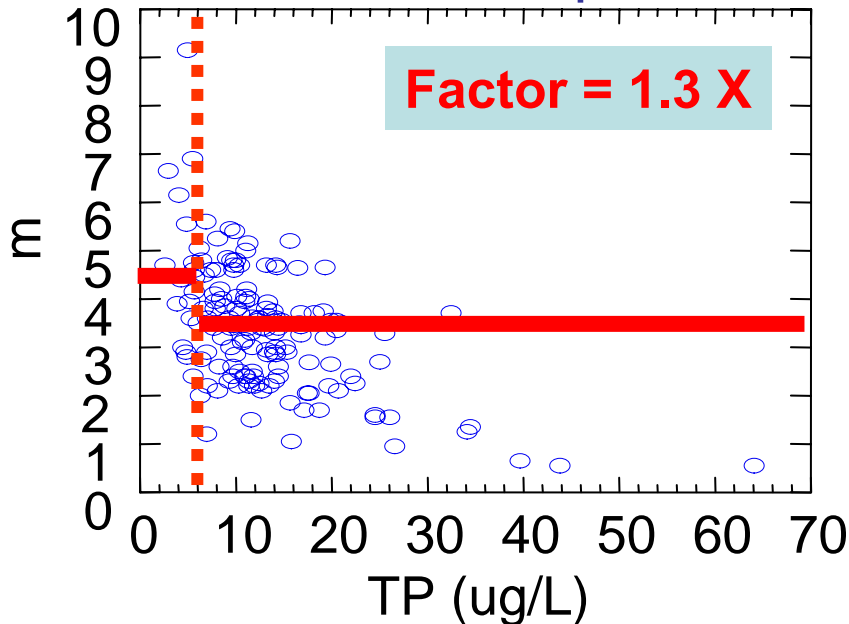

Phytoplankton biomass

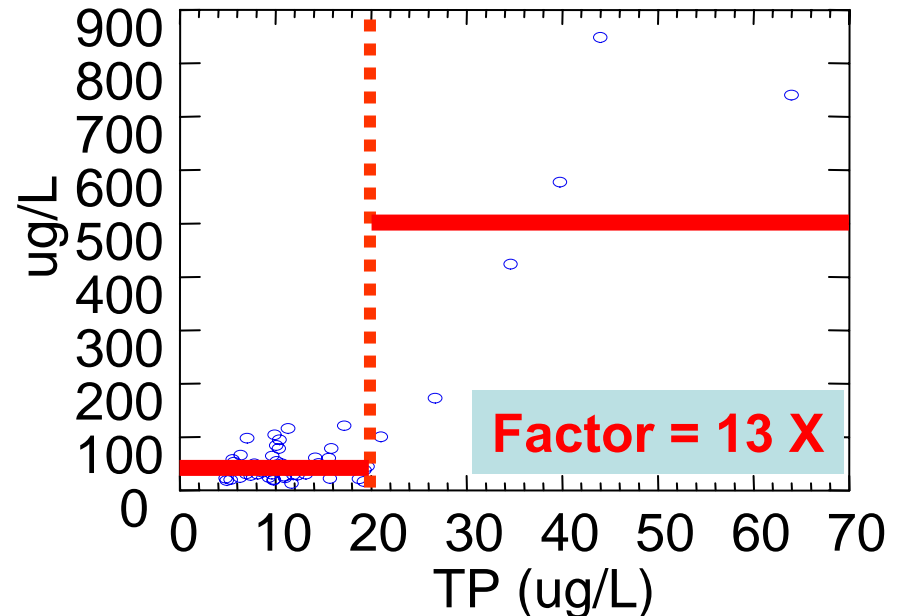

Choosing BIO benchmarks

Results for MI BIO datasets

**Relevant response
=> factor of 2**

BIO response	Risk:			
	1 %	10 %	50 %	
Phytoplankton/clarity	<u>Factor</u>	<u>Factor</u>	<u>Factor</u>	
Chlorophyll	2.4	6.7	17	140
Phyto biom.	3.2	13	17	56
Ext. coeff.	1.4	3.3	4.7	64
Secchi	1.3	1.3	1.3	153
Zooplankton				
Clad Len	1.7	1.6	1.6	43
% Daph Biom	96	97	120	28
Zoop Biom	3.4	3.5	1.7	28

Choosing BIO benchmarks

Results for MI BIO datasets

**Relevant response
= > factor of 2**

BIO response	Risk:			
	1 %	10 %	50 %	
Phytoplankton/clarity	<u>Factor</u>	<u>Factor</u>	<u>Factor</u>	
Chlorophyll	2.4	6.7	17	140
Phyto biom.	3.2	13	17	56
Ext. coeff.	1.4	3.3	4.7	64
Secchi	1.3	1.3	1.3	153
Zooplankton				
Glad Len	1.7	1.6	1.6	43
% Daph Biom	96	97	120	28
Zoop Biom	3.4	3.5	1.7	28

3. Identify thresholds in biological responses to TP

Choosing BIO benchmarks

Results for MI BIO datasets

Risk:

BIO response	1 %	10 %	50 %
Phytoplankton/clarity	<u>TP</u>	<u>TP</u>	<u>TP</u>
Chlorophyll	16	26	
Phyto biom.	16	20	
Ext. coeff.		21	
Secchi			
Zooplankton			
Clad Len			
% Daph Biom	9	11	
Zoop Biom	8	8	

Range:
16 – 26 → **21**

Range:
8 – 11 → **9**

The lake-specific nutrient criteria (LNC) approach

Overview

1. Model current lake TP

```
graph TD; A[1. Model current lake TP] --> B[2. Predict lake 'expected condition' (TP)]; B --> C[3. Identify thresholds in biological responses to TP]; C --> D[4. Use LNC algorithm to develop lake-specific criteria];
```

2. Predict lake 'expected condition' (TP)

3. Identify thresholds in biological responses to TP

4. Use LNC algorithm to develop lake-specific criteria

LNC Algorithm

Inputs:

CUR = current lake TP

EXP_A = 'expected' lake TP

BIO = BIO benchmarks
(TP = 9 & 21 ug/L)

4 RULES

(8 possible outcomes)

LNC Algorithm

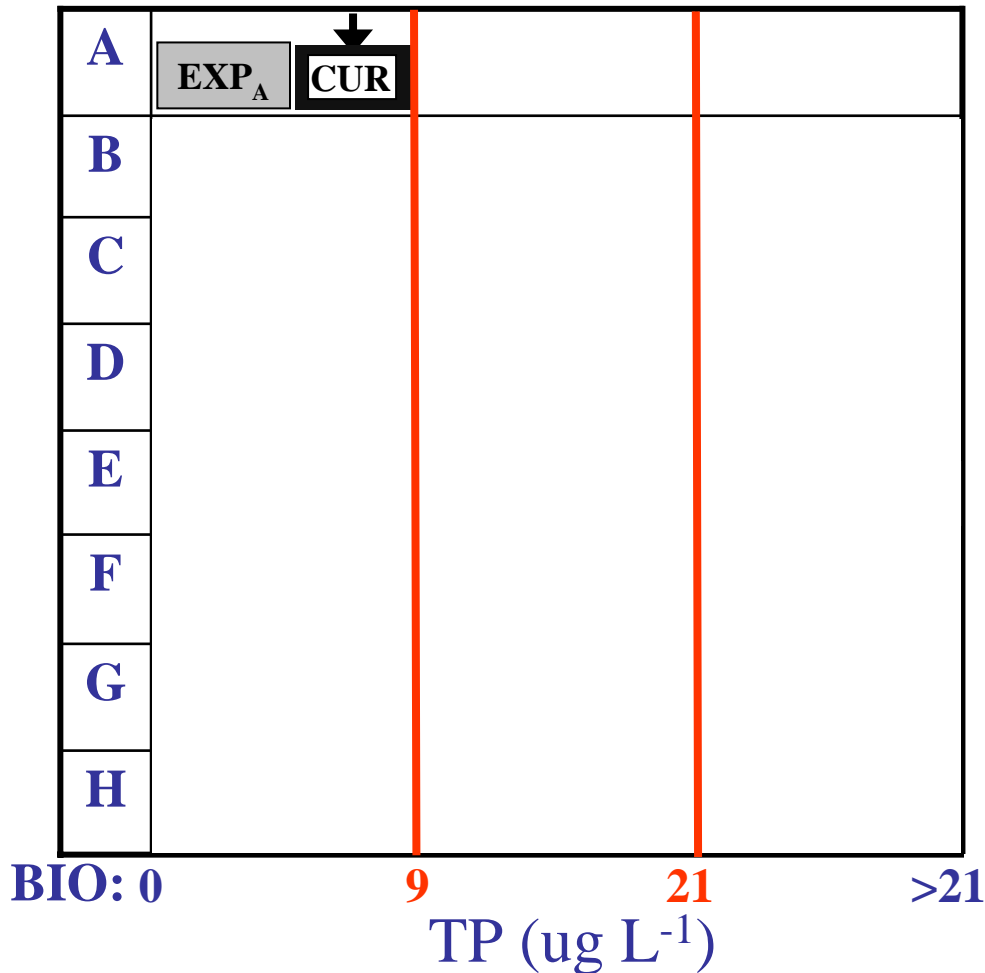

CUR = Current condition from lake sampling

EXP_A = Expected condition, with allowance

↓ = Nutrient criteria for given lake

LNC Algorithm

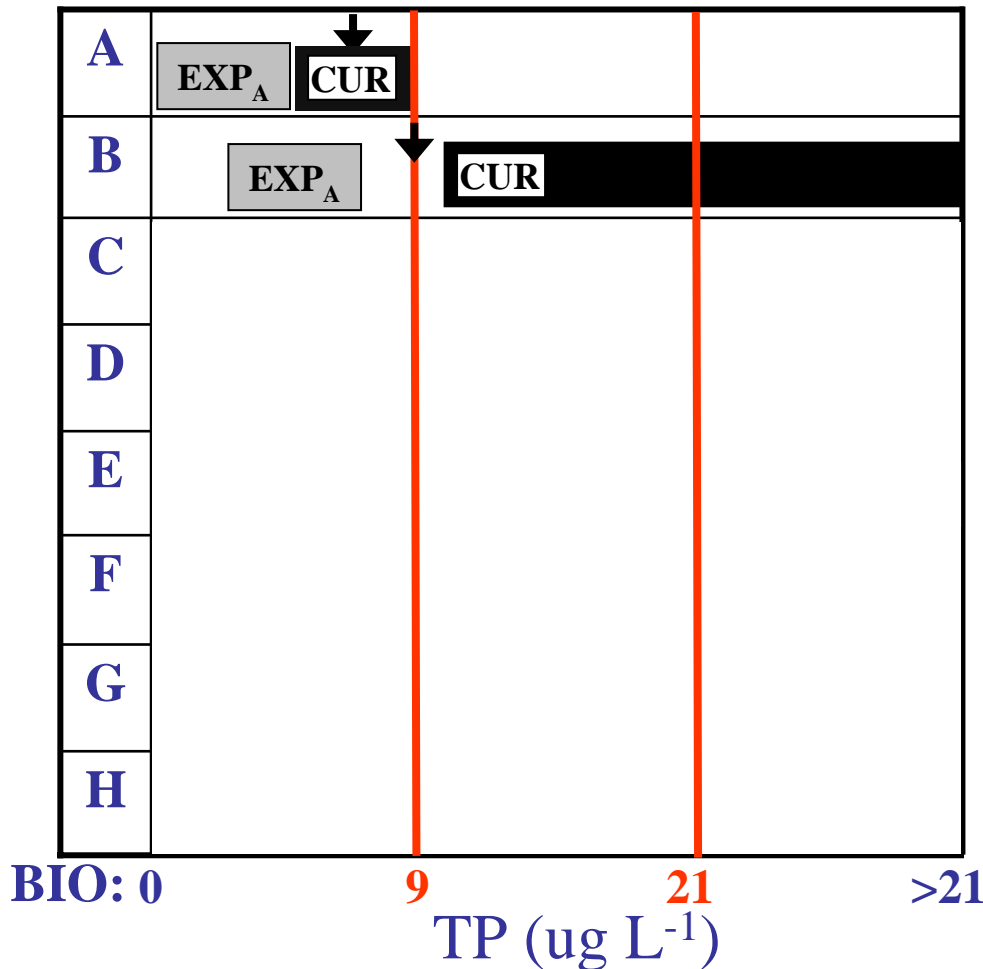

CUR = Current condition from lake sampling

EXP_A = Expected condition, with allowance

↓ = Nutrient criteria for given lake

4. Use LNC algorithm to develop lake-specific criteria

LNC Algorithm

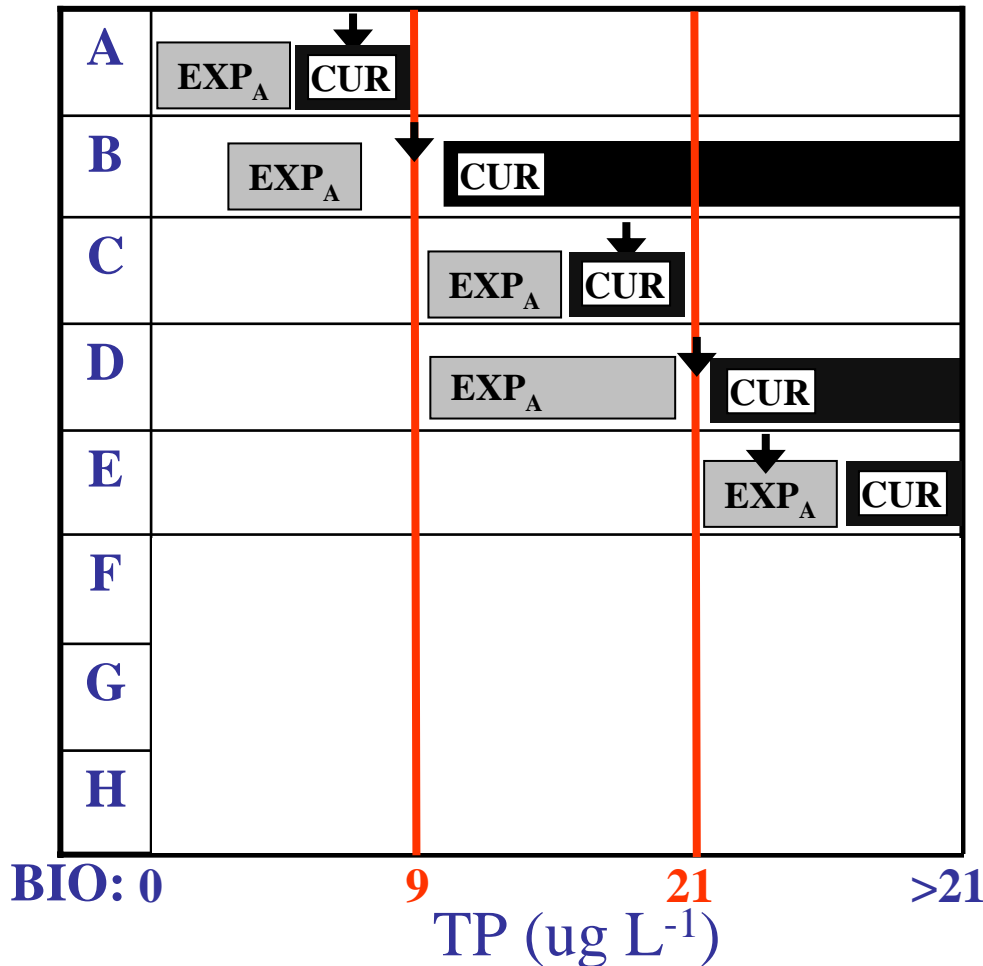

CUR = Current condition from lake sampling

EXP_A = Expected condition, with allowance

↓ = Nutrient criteria for given lake

4. Use LNC algorithm to develop lake-specific criteria

LNC Algorithm

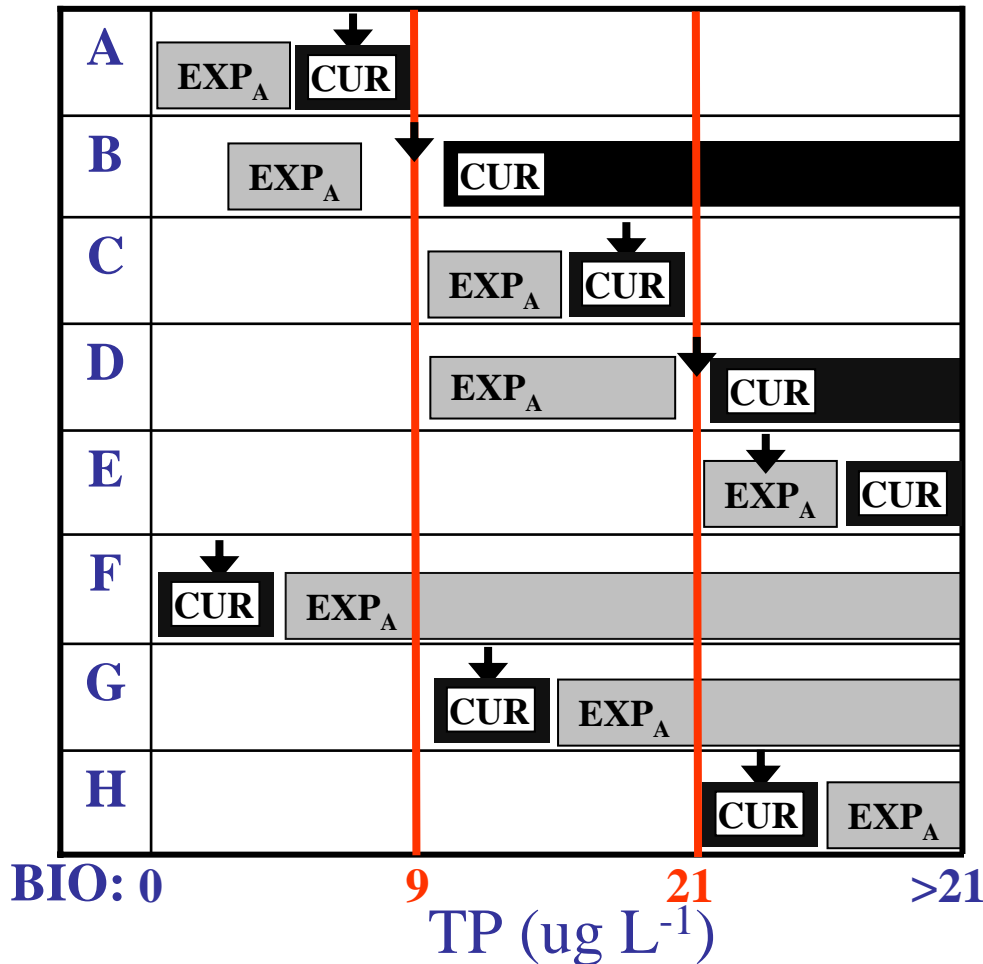

CUR = Current condition from lake sampling

EXP_A = Expected condition, with allowance

↓ = Nutrient criteria for given lake

4. Use LNC algorithm to develop lake-specific criteria

LNC Algorithm

Results for MI datasets

% of lakes:

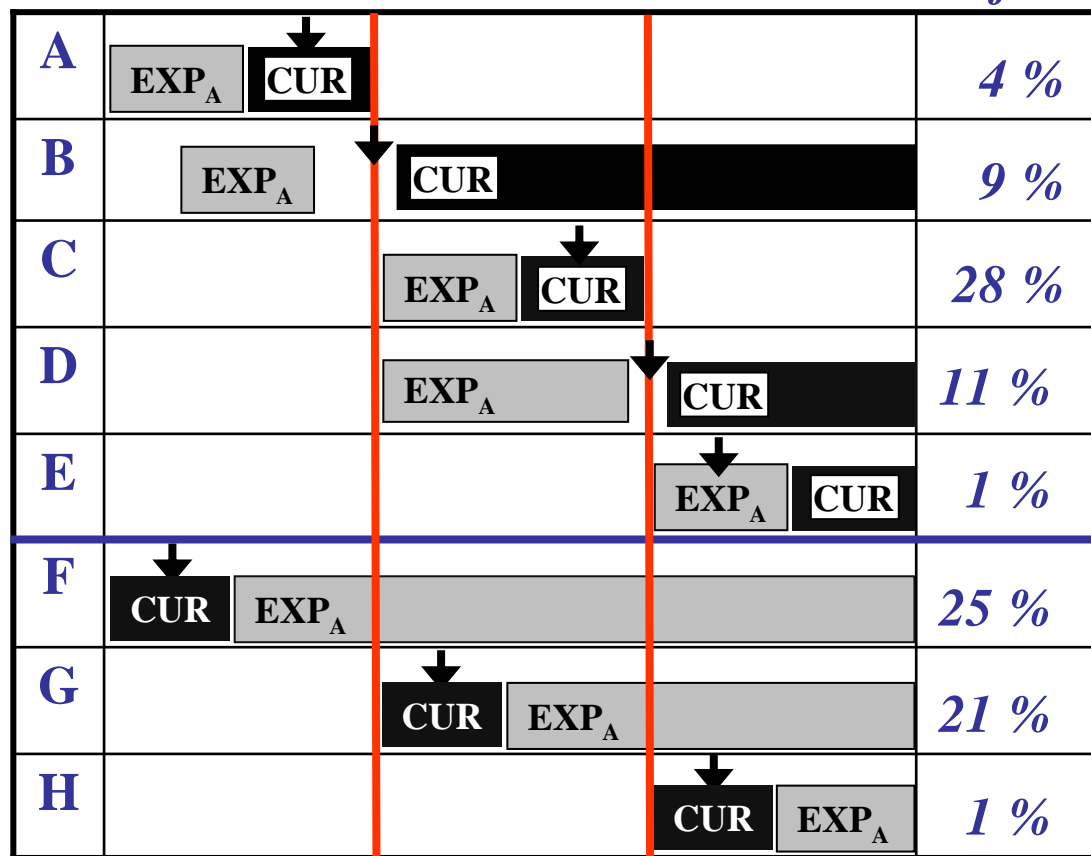

CUR = Current condition from lake sampling

EXP_A = Expected condition, with allowance

↓ = Nutrient criteria for given lake

BIO:0
 9
 21
 >21
 TP ($\mu\text{g L}^{-1}$)

*How does this compare to an
ecoregion approach??*

EPA regional values of 'reference' TP levels

**EPA Aggregate
Nutr. Ecoregion - VIII**

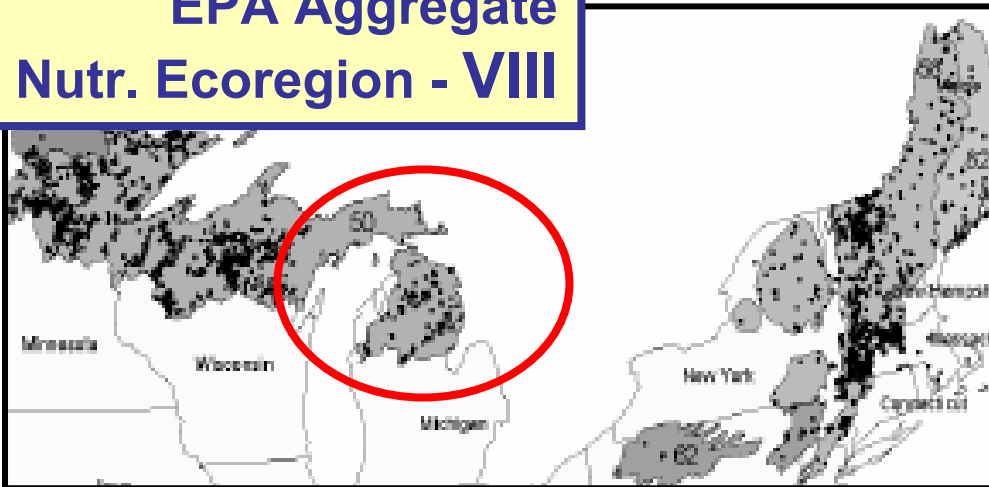

EPA-TP

8

**EPA Aggregate
Nutr. Ecoregion - VII**



15

EPA regional values of 'reference' TP levels

**EPA Aggregate
Nutr. Ecoregion - VIII**

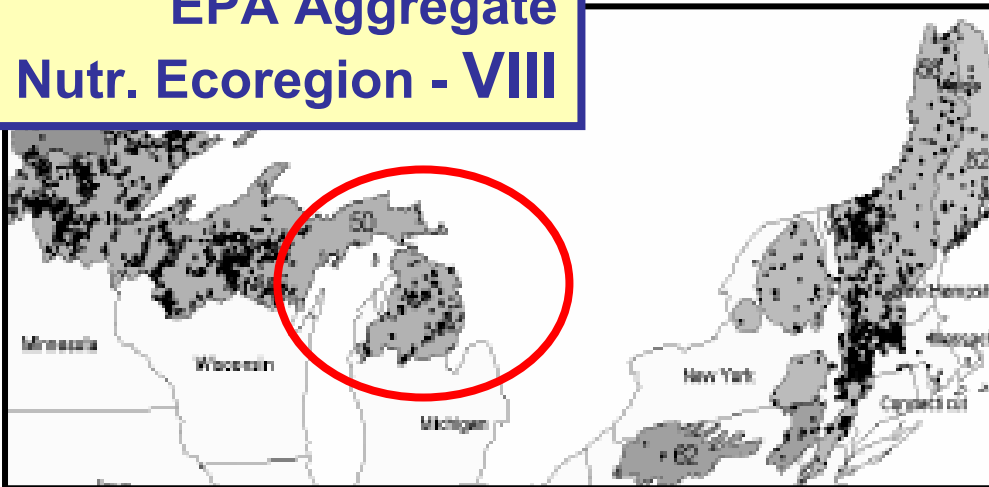

EPA-TP

EXP₀

8

7-11

**EPA Aggregate
Nutr. Ecoregion - VII**



15

7-11

EPA regional values of 'reference' TP levels

**EPA Aggregate
Nutr. Ecoregion - VIII**

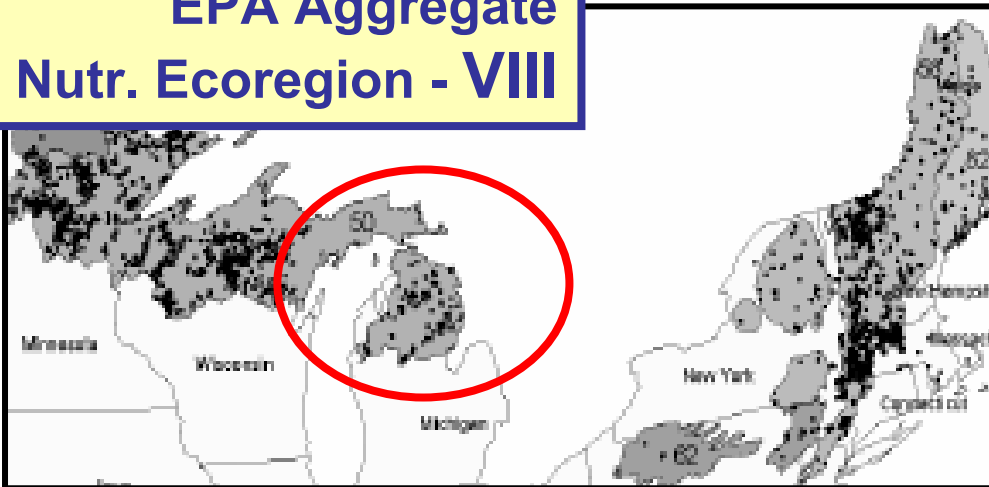

EPA-TP	EXP₀	EXP_A
8	7-11	9-15
15	7-11	10-14

**EPA Aggregate
Nutr. Ecoregion - VII**



Using an ecoregion approach for nutrient criteria?

Recommendations:

For statewide analyses,

- more 'local' variation, than 'regional' variation

For national analyses,

- 'regional' variation becomes important

(Cheruvilil et al., unpublished data)

Using an ecoregion approach for nutrient criteria?

% variation in TP at the regional spatial scale vs. local spatial scale

	Regional %	Local %
Michigan lakes	~10 %	90 %

(Cheruvilil et al., unpublished data)

Using an ecoregion approach for nutrient criteria?

% variation in TP at the regional spatial scale vs. local spatial scale

	Regional %	Local %
Michigan lakes	~10 %	90 %
6-state region*	~40 %	60 %

*MI, WI, IA, OH, NH, ME

(Cheruvilil et al., unpublished data)

Conclusions: *The LNC approach*

- (1) **REFERENCE LAKE VARIATION:** lakes vary in their reference TP, so nutrient criteria should be developed on a lake-by-lake basis
- (2) **BIOLOGICAL RESPONSES:** Incorporates biological responses into a single algorithm to determine TP criteria
- (3) **RISK:** Risk is incorporated into the benchmark-identification process, allowing policy makers to make a risk-level decision based on scientific evidence
- (4) **FLEXIBILITY:** As new data become available, they can be used through refinements of the HGM-LU model and the BIO benchmarks

(Soranno et al., under review at Limnology and Oceanography)